

Hyperdeck Accessories & Installation Guide

4*42mm

310 Stainless steel self-drilling screws.



50mm

310 Stainless steel drill bit.



200ml

Coating oil.



205*140*70mm

Metal side screw positioner.



205*100*55mm

Metal middle screw positioner.



50*50mm/40*60mm

Foamed PE joist.



Hyperdeck Accessories & Installation Guide

200*25mm*2440mm

PU composite decking bullnose board.



150*15*2400mm

PU composite decking side cover.



Fix the joists into the ground with
expansions screws.

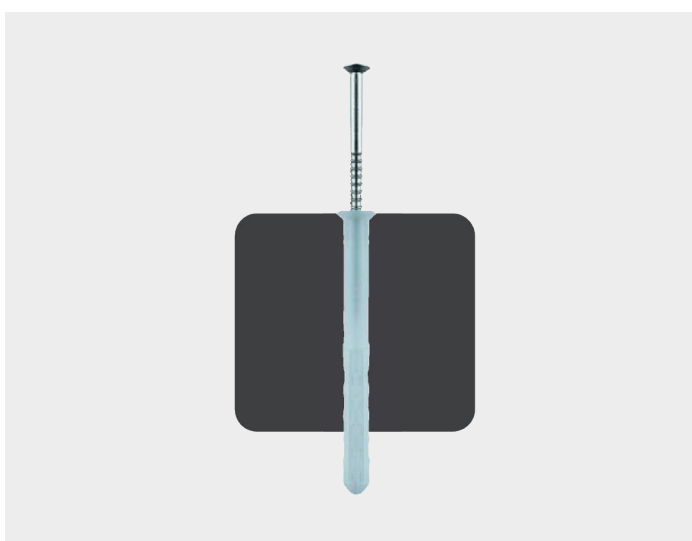

Keep the distance between the screws&joists
in 30-40cm.

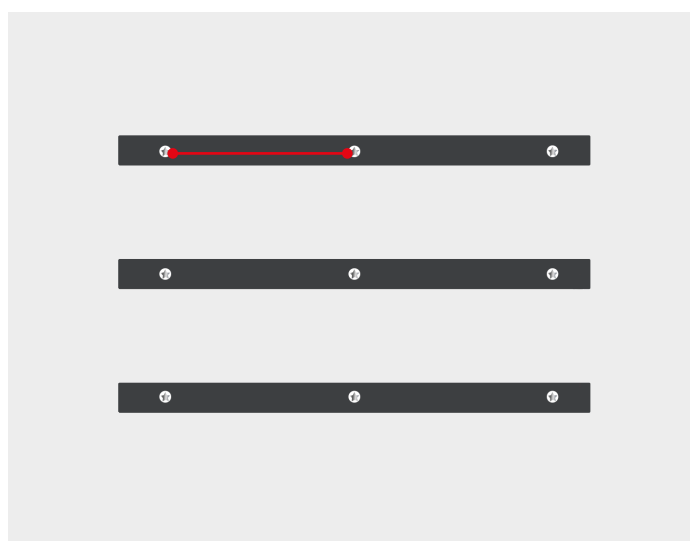

Hyperdeck Accessories & Installation Guide

STEP 1

Driving **screw** through the **holes of the side** screw positioner. By using the middle **screw positioner** to fix the decking onto the joists in the middle.

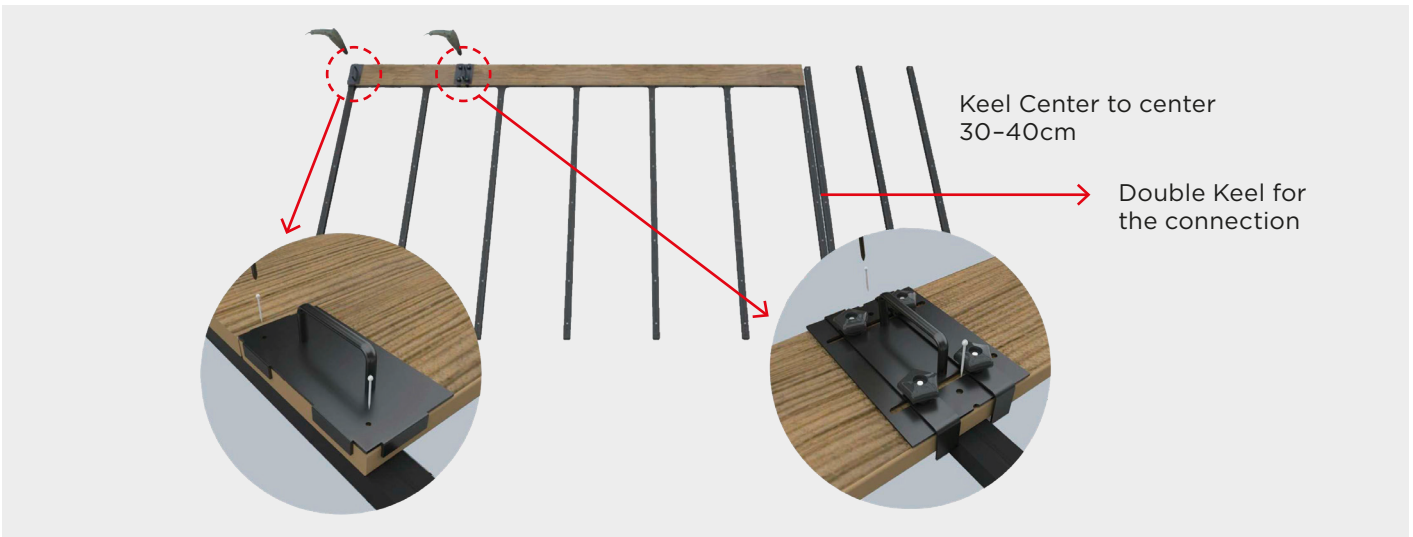

STEP 2

Both screw positioners keep a **3mm** space between the decking boards.

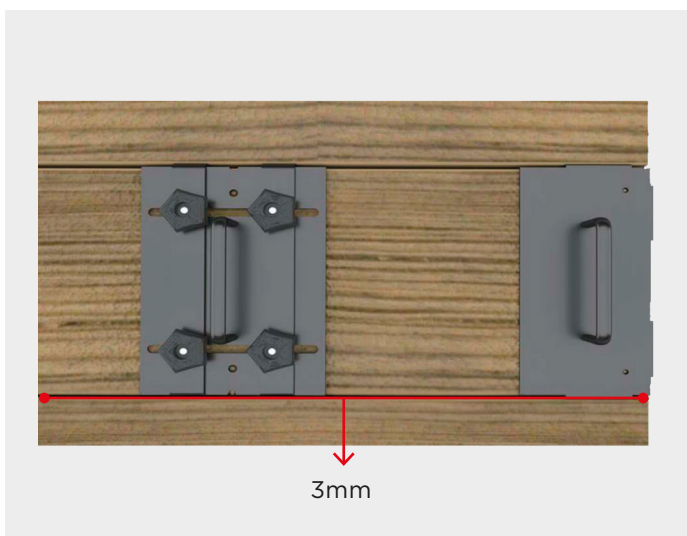

STEP 3

The decking boards can be **easily cut** with an electric saw to desired length.



Hyperdeck Accessories & Installation Guide

STEP 4

The cutting section can be painted with **Welltouch coating oil**.



STEP 5

Align the decking boards and **fix them** with the screws.



STEP 6

Repeat the steps till the whole installation is completed.



STEP 7

The ending piece can be either Welltouch decking board with a **vertical finish** or Welltouch bullnose board with a **curved finish**.



Hyperdeck Accessories & Installation Guide

BULLNOSE BOARD

